



**TOKIO MARINE**  
**HCC**

# **Tokio Marine HCC 2018 UK RS Feva Class Spring Championship**

*24 & 25 March 2018*

Draycote Water Sailing Club, Warwickshire, UK

## **SAILING INSTRUCTIONS**

### **1 RULES**

- 1.1 The regatta will be governed by the rules as defined in The Racing Rules of Sailing.
- 1.2 RRS 44.1 is changed so that the Two-Turns Penalty is replaced by the One-Turn Penalty.
- 1.3 The notation [DP] in a rule of the NoR or SI means that the penalty for breaching the rule is at the discretion of the protest committee.

### **2 COMMUNICATIONS WITH COMPETITORS**

- 2.1 There will be a briefing for competitors on Saturday 24 March at 11:30.
- 2.2 Notices to competitors will be posted on the official notice board, located at the front of the club house under the stairs.
- 2.3 Signals made ashore will be displayed from the flag masts located at the front of the club house adjacent to the race box.
- 2.4 When a visual signal is made over a flight flag (see instructions 2.8 and 3.2), it applies only to that flight.
- 2.5 [DP] Boats shall not leave the shore until flag D is displayed ashore. The warning signal will be made not less than 30 minutes after flag D is displayed. When the signal is displayed over a group flag (instruction 3.2), it applies only to that group
- 2.6 Any change to the format or schedule of races will be posted by 20:00 on the day before it will take effect and any change to the sailing instructions will be posted at least 30 minutes before flag D is displayed (instruction 2.5) on the day it will take effect.

- 2.7 The class flag will be the class insignia on a purple & grey background.  
 2.8 When racing in groups (instruction 3.2) there will be a group flag of that colour.

### 3 FORMAT OF RACING

- 3.1 The regatta will consist of a single series but the race committee may split the fleet as described below.  
 3.2 If the fleet is split, boats will be assigned to groups (Yellow, Blue, Red and White), of, as nearly as possible, equal size and ability. Assignments will be made by the organizing authority, and posted by 10:00 on the first day of racing. Groups will race with each other in rotation as follows:

<b>Race</b>	<b>First Start Groups</b>		<b>Second Start Groups</b>	
1	Yellow	Blue	Red	White
2	Yellow	Red	Blue	White
3	Yellow	White	Blue	Red
4	Red	White	Yellow	Blue
5	Blue	White	Yellow	Red
6	Blue	Red	Yellow	White

- 3.3 [DP] When racing in groups, boats shall display a streamer of the group colour from the masthead. Streamers will be provided by the organizing authority.

### 4 SCHEDULE OF RACES

- 4.1 The race schedule is as follows:

<b>Date:</b>	<b>Time of 1<sup>st</sup> warning signal &amp; scheduled races per day:</b>	
	<b>Time:</b>	<b># Races:</b>
Sat 24 Mar	12:30	3
Sun 25 Mar	11:00	3

- 4.2 The warning signal for each succeeding race will be made as soon as practicable.  
 4.3 To alert boats that a race will begin soon, the orange starting line flag will be displayed with one sound at least five minutes before a warning signal is made.  
 4.4 On the last day of the regatta no warning signal will be made after 15:00.

### 5 RACING AREAS

- 5.1 The racing area will be Draycote Water.

### 6 THE COURSES

- 6.1 The diagrams in Attachment A show the courses, the course designations, the approximate angles between legs, the order in which marks are to be passed, and the side on which each mark is to be left.  
 6.2 The gates 3S/3P and 4S/4P may be replaced by single marks to be left to port.  
 6.3 No later than the warning signal, the race committee signal boat will display the course designation.  
 6.4 To change the next leg of the course, the race committee will move the original mark (or the finishing line) to a new position, or lay a new mark and remove the original mark as soon as practicable.

### 7 MARKS

- 7.1 Marks 1, 2, 3S, 3P, 4S, 4P and 5 will be orange inflated marks.  
 7.2 New marks, as provided in instruction 6.4, will be of the same shape and colour as the original marks.

- 7.3 Starting marks will be a race committee signal boat at the starboard end, and a boat or buoy with an orange flag at the port end.
- 7.4 Finishing marks will be a race committee boat and a buoy with a blue flag.

## **8 THE START**

- 8.1 The starting line will be between staffs displaying orange flags on the starting marks.
- 8.2 [DP] Boats whose warning signal has not been made shall avoid the starting area during the starting sequence for other races.

## **9 THE FINISH**

The finishing line will be between staffs displaying blue flags on the finishing marks.

## **10 TIME LIMITS & TARGET TIMES**

- 10.1 The time limit and target time in minutes is as follows:

<i><b>Time limit</b></i>	<i><b>Finish window</b></i>	<i><b>Target time</b></i>
60	10	40

Failure to meet the target time will not be grounds for redress. This changes rule 62.1(a).

- 10.2 Boats failing to finish within the finish window time after the first boat sails the course and finishes will be scored according to their observed position on the course, which may be the position at the last mark rounded. This changes rules 35, A4 and A5.

## **11 PROTESTS, PENALTIES & REQUESTS FOR REDRESS**

- 11.1 Protest forms are available at the race office. Protests and requests for redress or reopening shall be delivered there within the appropriate time limit.
- 11.2 The protest time limit is 45 minutes after the last boat has finished the last race of the day or the race committee signals no more racing today, whichever is later.
- 11.3 Notices will be posted no later than 30 minutes after the protest time limit to inform competitors of hearings in which they are parties or named as witnesses.
- 11.4 Notices of protests by the race committee, technical committee or protest committee will be posted to inform boats under RRS 61.1(b).
- 11.5 Penalties for breaches of class rules, RRS 55 or rules in the NoR and SIs marked [DP], are at the discretion of the protest committee.
- 11.6 Breaches of SI 13, Safety Regulations, will not be grounds for protest by a boat. This changes RRS 60.1(a).
- 11.7 On the last scheduled day of racing, a request for redress based on a protest committee decision shall be delivered no later than 30 minutes after the decision was posted. This changes RRS 62.2.

## **12 SCORING**

- 12.1 Two races are required to be completed to constitute a series.
- 12.2 (a) When fewer than four races have been completed, a boat's series score will be the total of her race scores.
- (b) When four or more races have been completed, a boat's series score will be the total of her race scores excluding her worst score.
- 12.3 When boats race in flights, rule A4.2 is changed so that the scores are based on the number of boats assigned to the larger flight.
- 12.4 A boat starting later than 4 minutes after her starting signal will be scored Did Not Start. This changes rules A4 and A5.
- 12.5 To request correction of an alleged error in posted race or series results, a boat may complete a scoring enquiry form available at the race office.

### **13 SAFETY REGULATIONS**

- 13.1 [DP] Competitors shall wear personal flotation devices at all times while afloat, except briefly while adjusting clothing or personal equipment.
- 13.2 [DP] A boat that retires from a race, or does not intend to start a race, shall notify the race committee as soon as possible.

### **14 REPLACEMENT OF CREW OR EQUIPMENT**

- 14.1 [DP] Substitution of competitors will not be allowed without prior written approval of the race committee.
- 14.2 [DP] Substitution of damaged or lost equipment will not be allowed unless authorised by the race committee. Requests for substitution shall be made to the committee at the first reasonable opportunity.

### **15 EQUIPMENT & MEASUREMENT CHECKS**

On the water, a boat can be instructed by a member of the race committee or technical committee to proceed immediately to a designated area for inspection. Equipment may be inspected at any time in accordance with NoR 7.

### **16 SUPPORT BOATS**

[DP] Support persons shall stay outside areas where boats are racing from the time of the preparatory signal for the first class to start until all boats have finished or retired or the race committee signals a postponement, general recall or abandonment.

### **17 RADIO COMMUNICATION**

[DP] Except in an emergency, a boat that is racing shall not make voice or data transmissions and shall not receive voice or data communication that is not available to all boats.

### **18 PRIZES**

Prizes will be awarded, depending on entry numbers.

### **19 INSURANCE**

Each participating boat shall be insured with valid third-party liability insurance with a minimum cover of £ 2 million per event or the equivalent

### **20 RISK STATEMENT**

- 20.1 Rule 4 of the Racing Rules of Sailing states: "The responsibility for a boat's decision to participate in a race or to continue racing is hers alone."
- 20.2 Sailing is by its nature an unpredictable sport and therefore inherently involves an element of risk. By taking part in the event, each competitor agrees and acknowledges that:
- (a) They are aware of the inherent element of risk involved in the sport and accept responsibility for the exposure of themselves, their crew and their boat to such inherent risk whilst taking part in the event;
  - (b) They are responsible for the safety of themselves, their crew, their boat and their other property whether afloat or ashore;
  - (c) They accept responsibility for any injury, damage or loss to the extent caused by their own actions or omission;
  - (d) Their boat is in good order, equipped to sail in the event and they are fit to participate;
  - (e) The provision of a race management team, patrol boats and other officials and volunteers by the event organizer does not relieve them of their own responsibilities;
  - (f) The provision of patrol boat cover is limited to such assistance, particularly in extreme weather conditions, as can be practically provided in the circumstances.

- (g) It is their responsibility to familiarize themselves with any risks specific to this venue or this event drawn to their attention in any rules and information produced for the venue or event and to attend any safety briefing held for the event.
- (h) Their boat is adequately insured, with cover of at least £2 million against third-party claims, or the equivalent in other currencies.

**Attachment A**  
**COURSE DIAGRAMS**

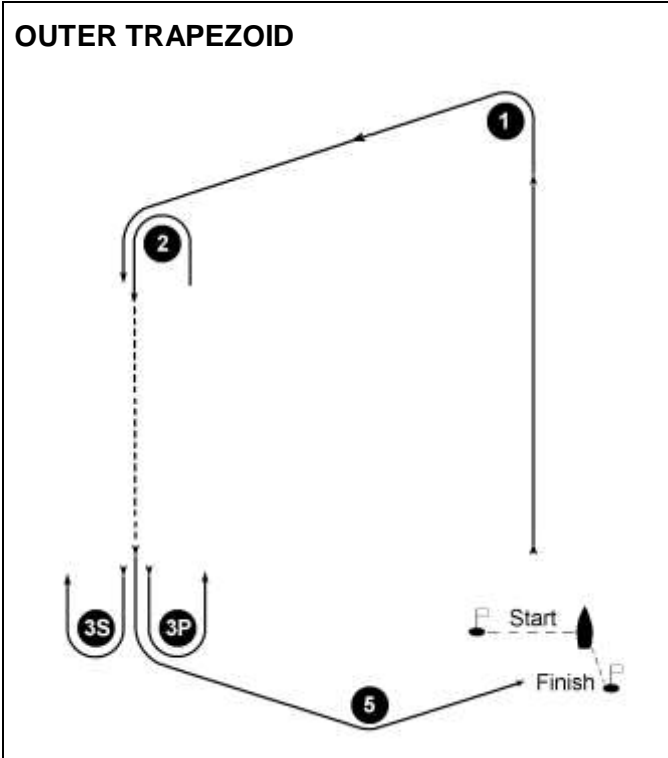

**Signal Mark rounding order**

**O2 Start – 1 – 2 – 3s/3p – 2 – 3p – 5 – Finish**

**O3 Start – 1 – 2 – 3s/3p – 2 – 3s/3p – 2 – 3p – 5 – Finish**

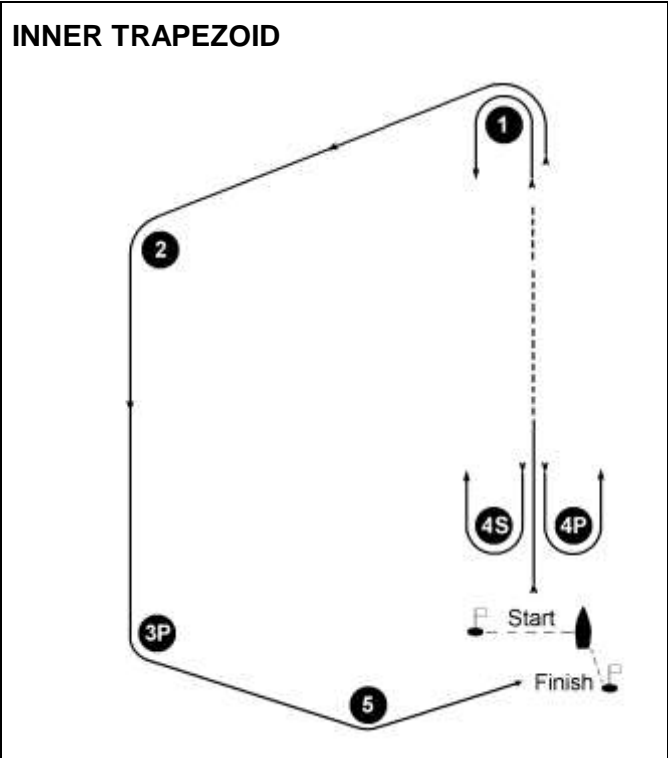

**Signal Mark rounding order**

**I2 Start – 1 – 4s/4p – 1 – 2 – 3p – 5 – Finish**

**I3 Start – 1 – 4s/4p – 1 – 4s/4p – 1 – 2 – 3p – 5 – Finish**

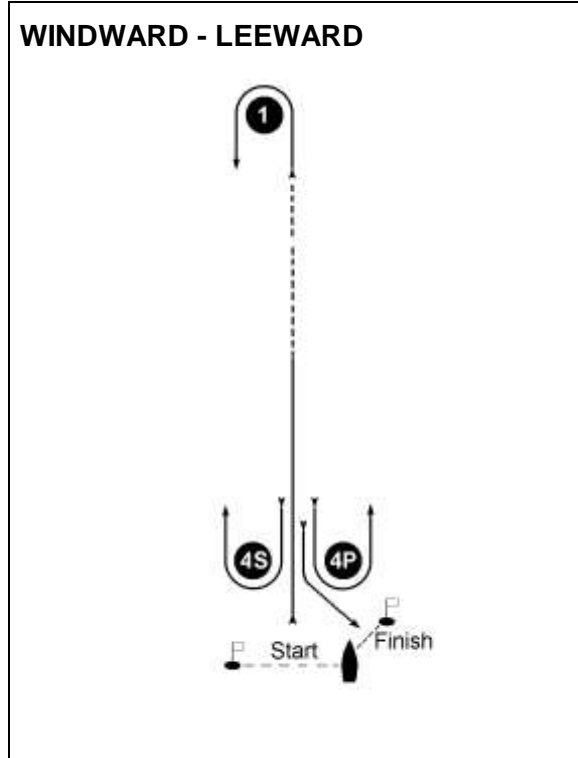

**Signal Mark rounding order**

**L2 Start – 1 – 4s/4p – 1 – 4p – Finish**

**L3 Start – 1 – 4s/4p – 1 – 4s/4p – 1 – 4p – Finish**